

A VISION UPON PLM AS STRATEGIC INSTRUMENT FOR CONCURRENT ENGINEERING AND FOR SUSTAINABLE PRODUCT DESIGN

Vasile Merticaru jr., Gavril Muscă

Technical University "Gh. Asachi" of Iasi, Romania
email: merticaru@tcm.tuiasi.ro

ABSTRACT

A lot of specialists, both academia and industrials, agree that nowadays Romanian manufacturing industry is forced to unprecedented transformations, determined by the complex present conditions of European integration. Of course, trends like globalization and products complexity growing, in the sense of their variety, have important impacts upon production and upon all its support functions. Productive companies such as machine manufacturing enterprises usually have to manage a great number of variants in their product portfolios and they also must be agile and achieve short delivery times, as long as most of the customers ask for specific, individually developed solutions, within a fast changing market environment. The present paper comes to emphasize a vision upon PLM as a strategic instrument for concurrent engineering and for sustainable product design, basing on the results of a research experiment of implementing a PLM solution within a network composed of technical universities, research institutes and productive enterprises. In this context, PLM is outstood as a sustaining pillar for the discrete manufacturing in the productive company, entirely able to help in solving the above mentioned problems, no matter that there still exists considerable confusion among the specialists from enterprises as IT users, concerning the usefulness of the related software applications. On the other hand, there is presented in the paper that the concept of Sustainable Product Design must be considered in relation with Life Cycle Analysis (LCA) and with the Extended Producer Responsibility (EPR). The concepts of Reducing, Reusing, Recycling and Recovery of material resources are also nominated as being very important in providing Sustainable Product Design.

KEYWORDS: PLM, product design, concurrent engineering, sustainable design

1. PROBLEM STATEMENT

1.1. Present realities in Romanian industry and research institutions

A lot of specialists, both academia and industrials, agree that nowadays Romanian manufacturing industry and also the research institutions are forced to compulsory unprecedented transformations, determined by the complex present conditions of European integration. Of course, trends like globalization and products complexity growing, in the sense of their variety, have important impacts upon production and upon all its related support functions.

Productive companies such as machine manufacturing enterprises usually have to manage a great number of variants in their product portfolios and they also must be agile and achieve short delivery times, as long as most of the customers ask for specific, individually developed solutions, within a continuous and fast changing market environment.

The same situation must be faced by the Romanian research institutes, which have to manage a great deal of data, most of it reusable, in their projects.

There must not be forgotten the need of performing in a strongly competing market environment and lately within a climate of global financial crisis.

In these hard economic conditions, each Romanian enterprise, starting with the SME-s and finishing with the subsidiaries of great international corporations and of course each of the research institutions, can no longer afford to wait time repeating tasks, thereby prolonging the time it takes to bring new products or projects to the market.

Of course, considering the need of the economic agents for conceiving and producing economical, qualitative, and aesthetical products, the specialists and researchers from technical universities may assume time consuming tasks such as execution of technical documentation and draft drawings, conception of the products' ergonomics and not at last of aesthetics, simulation of the products behaviour using FEM instruments, generation and testing of the technologies for CNC machine-tools using the facilities of various CAM systems.

At the same time, the continually increasing interest in CAD designing activities based on solid entities obviously occurs both for students from technical universities, [7], and for designers from many companies specialized in design and manufacturing. The large numbers of CAD files and of a lot of other appendix documents which form complex projects determine the need for the development of on-line collaboration platforms in the field of computer aided mechanical design and computer aided engineering. Collaborative development of large engineering projects indicates as very actual the idea that more and more participants in the projects development, specialized in the areas of design, manufacturing, marketing, presentation, sales and maintenance of products perceive the product development as a social activity, of collaboration between different specialists.

From another point of view, the access to continue renewing technologies and especially IT have brought, also for Romanian society, radical changes in the global visions and ways of thinking about products, manufacturing systems and processes, business environment and, not at last, about our living environment. In these conditions, the concept of Sustainable Development, as well as all the other related concepts, becomes very important also for Romanian scientific and industrial environment.

1.2. Need for concurrent engineering and for sustainable product design

For concluding the above presented considerations, we can say that in today's business world, also Romanian manufacturing enterprises and research institutions must be able to responsively react to the changing market needs in a rapid and effective manner. They must be able to adapt to the changing environments and reduce their time to market. All their decisions must be made quickly and they must be done right the first time out, [8]. Therefore, concurrent engineering has emerged as

way of bringing rapid solutions to product design and development process, [16].

On the other hand, from the industrial point of view, it is largely accepted that for accomplishing the crucial goal of Sustainable Development, just since it has become more and more a global challenge and goal, there must be started with Sustainable Manufacturing. This imperative determines more and more industrials, all over the world and step by step also in Romania, to adapt their activities to integrated engineering and integrated manufacturing.

Further on, engineering specialists largely accept that for achieving the goal of sustainable manufacturing there must be started with designing activities. In other words, they say that we will go to Sustainable Development via Sustainable Design. Sustainable Design, as the most modern design concept, might be define in various ways. In a few words, Sustainable Design is the art of creating Virtual Products (as the base for Physical Products) or any other similar activity able to assure a harmony between profit, people and planet, [4].

Finally, but not at last, there must be mentioned here that passing from the Information Age towards the Relationship Age, determines all the organizations to permanently focus on their relationships and information exchange with partners, suppliers, customers, employees and investors, [3].

1.3. PLM systems – the proposed solution for helping

From the above presented points of view, the present paper comes to further on propose PLM (Product Lifecycle Management) systems as a helpful solution for concurrent engineering and for sustainable product design.

The need for developing complex mechanical projects in local or collaborative networks requires familiarity of the product developers with the procedures of technical data management. There are necessary skills for on-line development of product components and assemblies, for integrating with communication channels, for accelerating data exchange.

In these conditions, the experience of some teams for the implementation of some PLM systems shows that training and formation of specialists in PDM/PLM area is a current necessity, [12].

2. BRIEF OVERVIEW ON RELATED WORLDWIDE SITUATION

At the present time, many important PLM software companies are acting on the profile market. Among them, we can nominate the following: Siemens, SAP, PTC, Oracle, Dassault Systemes, Arena Solutions, etc. Their research and business activities gave as result major PLM systems, including the following examples: TeamCenter,

Windchill, SmarTeam, SAP PLM, Sherpa, Metaphase, I-man, Enovia, eMatrix, Eigner, Arena, Agile. As a particular example, an overall image upon

the offer of PLM solutions from GeometricGlobal, [5], is presented in Fig. 1.

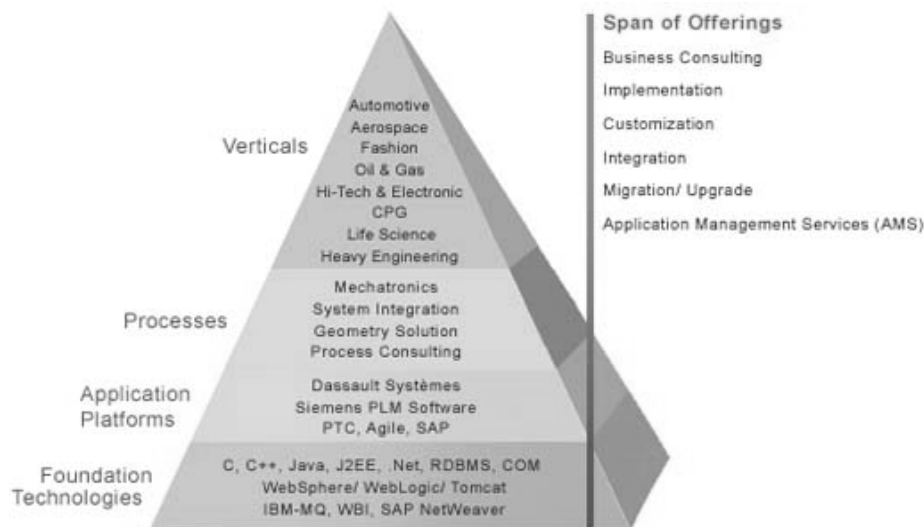

Fig.1. Offer of PLM solutions from GeometricGlobal, [5]

PLM systems as the ones mentioned above have been released and implemented within a lot of organizations. We can nominate here important corporations from automotive industry, like Volkswagen in Germany, Renault in France, Toyota in Japan and also from aeronautical industry, like Airbus or Boeing etc.

For such corporations, PLM systems come to help in solving complex problems mainly like internal and inter-organizational collaboration for product development.

3. BRIEF OVERVIEW ON RELATED NATIONAL SITUATION

During the last few years, also within Romanian industrial and research environment, PLM systems come to have success, being appealed to help in solving problems like the following: technical data management for project development; management of the activities of working team members, respectively tasks distribution and ways for their accomplishing; grouping of data from compartments of engineering design, technological design, tooling design, product manufacturing and assembling.

Examples of PLM systems implementations in Romanian economy can be met mainly in subsidiaries of international manufacturing corporations or in companies with foreign partners, like the following: enterprises which produce automotive component parts, being actors in the outsourcing industry from automotive field, an example in this sense being COMPA Sibiu, with German partnership; enterprises from refrigerators industry, like Arctic Găești, having

Turkish partnership; enterprises from furniture industry, like in Cluj-Napoca etc, [6].

Some implementations of PLM solutions have started to be developed also in the academic research environment, within university networks, like the project INPRO in Timisoara or the project RECOAS in Iasi, [13, 14].

4. RESEARCH APPROACH

4.1. Research basic idea

The research basic idea of the paper was to experiment the implementation of a PLM solution within a network composed of technical universities, research institutes and productive enterprises. The experiment has targeted the generation of projects and products using the concepts of CAD/CAM/CAE and data management at the network's level using PDM/PLM systems.

The main goal of the research have been to evidence PLM systems as a sustaining pillar for the discrete manufacturing in the productive company, entirely able to help in solving its product development problems.

In relation to this idea, we mention that analysts, IT specialists and IT solutions vendors outstood, a few years ago, a lean strategic vision, [2], upon the discrete manufacturing in the frame of Computer Integrated Enterprise - CIE. Accordingly to this vision, PLM (Product Lifecycle Management), SCM (Supply Chain Management), CRM (Customer Relationship Management) and ERP (Enterprise Resources Planning) are identified as being the four

cornerstones in the frame of an enterprise's IT structure or as being the four sustaining pillars for the discrete manufacturing in the user company, [9, 11], as it is shown in Fig. 2.

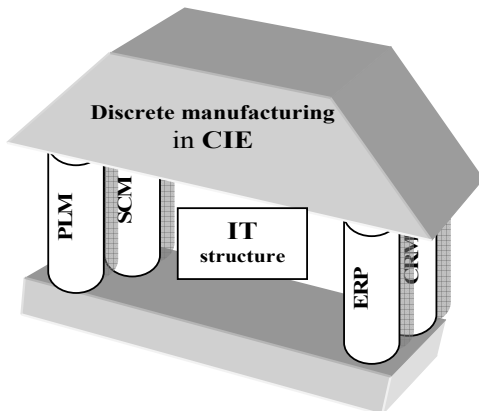

Fig.2. PLM in the lean vision on CIE

4.2. PLM systems – more than strategic instrument for concurrent engineering

An important aspect to be nominated is that based on research statistical data, there are specialists who announce that up to 90% of all design activities are based on the variants of existing designs, [1].

In these conditions, switching from the classic idea of concurrent engineering towards PLM systems seems to be the best alternative. As principle, concurrent engineering means multidisciplinary team and simultaneous development of the project. PLM principle means more than this, respectively on-line working of the teams on a common model from a unique database, [15].

4.3. PLM concept and systems in relation with LCA and EPR concepts

In the frame of CIE, we firstly must consider the Sustainable Industrial Design in relation with Life Cycle Analysis (LCA), by following the ‘‘cradle-to-cradle’’ way, [10], as it is shown in Fig.3.

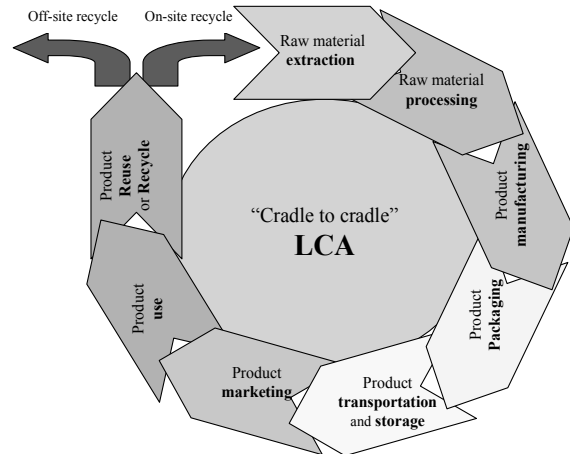

Fig.3. LCA based on ‘‘cradle-to-cradle’’ concept

Secondly, Sustainable Industrial Design must be considered in relation to the Extended Producer Responsibility (EPR) and in this sense, the Cleaner Production techniques must be also considered into Integrated Engineering and into concurrent engineering, [10], as it is shown in Fig. 4.

Some other concepts, such as those of Reducing, Reusing, Recycling and Recovery of material resources are also very important in providing Sustainable Industrial Design.

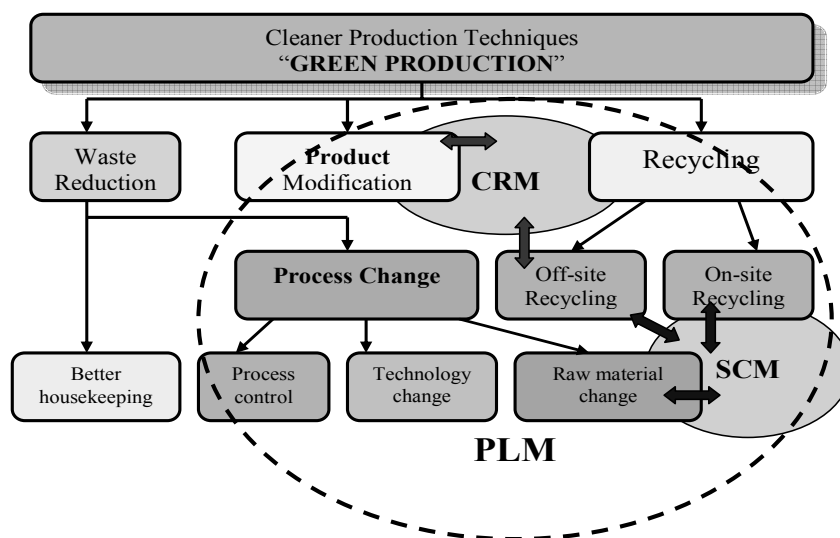

Fig.4. Cleaner Production techniques and their superposing with PLM area

4.4. Research experiment

As research experiment, there are further on presented in the paper the efforts of a team from the CAD/CAM/PLM Laboratory from Technical University ‘‘Gh. Asachi’’ of Iasi for collaborative development of some industrial projects.

The research experiment consisted more exactly in the implementation of a PLM solution within a network formed of technical universities, research institutes and productive enterprises, intending to create a better collaboration between the universities and economic agents to solve the following problems:

- CAD,
- Design and ergonomics of the product,
- Simulation of the functioning behaviour using FEA,
- Conception of the manufacturing technology CAM.

The stages followed for implementing a PLM solution into a network formed by universities and manufacturing enterprises were:

- the knowledge acquisition and the development of skills for using CAD systems;
- achieving to know and understand the concept of data management and to establish some procedures for implementation at the level of functional areas into an industrial enterprise;
- establishment of the soft and hard structure of the system used for data management;
- the training of the staff involved in the activity of products’ conception, design and manufacturing.

The CAD projects developed within the research experiment have been done using SolidEdge. A few of such projects have been done for stamping devices as it is exemplified in Fig. 5 and Fig. 6.

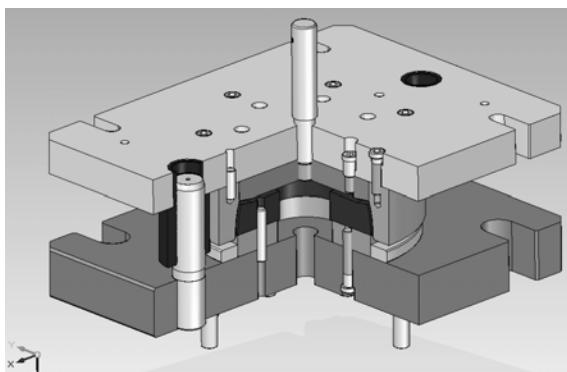

Fig.5. Example of project developed within the research experiment – Stamping device

TeamCenter software environment has been used as PLM solution, for data management, within the research experiment. An example of its use is presented in Fig.7.

Integration of the PLM environment was realized within a VPN network providing all the required collaborative development conditions.

The optimization of the structure of the approached designs of products has used both the facilities of SolidEdge as CAD solution and of the TeamCenter environment as PLM solution.

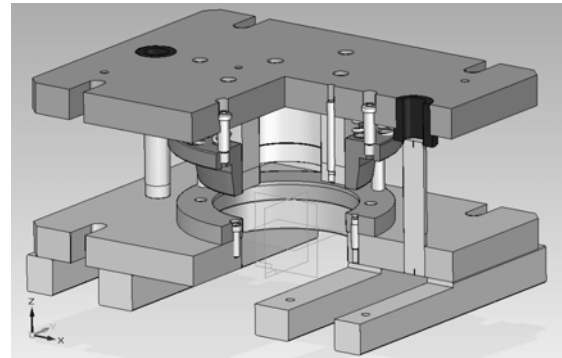

Fig.6. Example of project developed within the research experiment – Stamping device

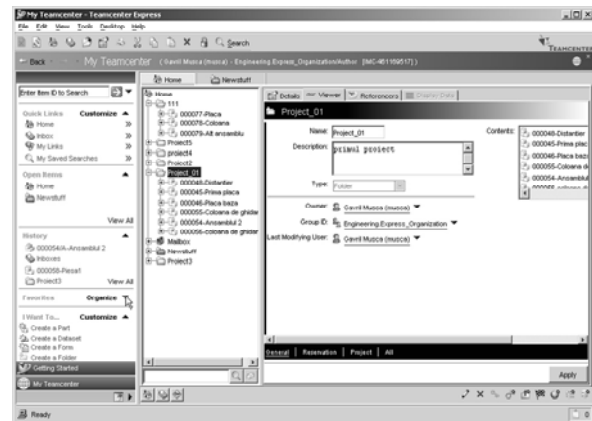

Fig.7. User interface in TeamCenter, PLM solution used in research experiment

Within the research experiment, several project variants have been developed for different type projects of stamping devices. Each of the variants had different dimensions and components, being available for further development.

The completion of a certain project has been done by analyzing the workability of the parts processed by stamping, the design of the scheme for placing the parts on the sheet metal strip, the establishment of the processing phases. Considering the analysis of these elements, one of the previously designed variants is used, which by configuration and dimensions frames the working scheme developed for a stipulated part. Then, the punches and the active elements are designed and function of those, the active plate and the port-punch plate are adapted. The elements for material guidance, the fixing-retaining during processing and the evacuation of the stamped elements are further on developed.

Further on, using the facilities of the data management systems, project variants have been developed, characterized by codification of assemblies, sub-assemblies and components. These variants are available in final or archived variant.

5. CONCLUSIONS

The present paper comes to emphasize a vision upon PLM as a strategic instrument for concurrent engineering and for sustainable product design.

In this sense, the implementation of TeamCenter software environment, as a PLM solution, within a network composed of technical universities, research institutes and productive enterprises has been experimented. Within the experiment, the generation of projects and products using the concepts of CAD/CAM/CAE and data management at the network's level, using SolidEdge and TeamCenter, has been performed.

The research experiment has proved that in such an implementation some malfunctions can be found, caused by:

- insufficient number of persons with abilities in the CAD/CAM/CAE area;
- inefficient education of the specialists in this domains and of the students, as the work with a CAD system requires to go through a training stage that must be individually realized;
- differences between the team members regarding the knowledge level, which lead to difficulties in collaborative activity.

Also, the research experiment has made possible to conclude that the premises of forming a team efficient in work in the virtual environment are based on the following:

- adequate level of knowledge for accomplishing the tasks for the main stages of the product lifecycle, CAD, CAM, relationships with the suppliers and customers;
- motivation of the team working by co-interesting and counselling in the domain of PDM/PLM.

The main conclusion has been that the success in the activity of implementation of mechanical projects developed in CAD environments is determined also by knowing the procedures for the management of CAD files, of revisions and of their modification.

In this context, PLM is outstood as a sustaining pillar for the discrete manufacturing in the productive company, entirely able to help in solving the above mentioned problems, no matter that there still exists considerable confusion among the specialists from enterprises as IT users, concerning the usefulness of the related software applications.

On the other hand, there is presented in the paper that the concept of Sustainable Product Design must be considered in relation with Life Cycle Analysis (LCA) and with the Extended Producer Responsibility (EPR). The concepts of Reducing, Reusing, Recycling and Recovery of material resources are also nominated as being very important in providing Sustainable Product Design.

REFERENCES

- [1] **Abramovici, M., Meimann, V.**, *Quality Management for Virtual Products*, Academic Journal of Manufacturing Engineering, Vol.6, issue 3/2008, Ed. Politehnica, Timisoara, pp.6-12, ISSN 1583-7904;
- [2] **Evans, M.**, *In 2004, will PLM and SCM still be recognisable TLAs?* Available from: http://www.cambashi.com/research/plm_debate/plm_scm.htm. Accessed: 2007-12-12.
- [3] **Galbreath, J.**, Success in the Relationship Age: Building Quality Relationship Assets for Market Value Creation, *The TQM Magazine*, Vol.14, No.1, pp.8-24.
- [4] **Galis M.** et al., *Digital product development for the entire product life cycle*. Academic Journal of Manufacturing Engineering, vol. 6, issue 3/2008, Timisoara, Romania, p.55-60;
- [5] **GeometricGlobal**, *Extended PLM Vision*, Available from: <http://plm.geometricglobal.com/Extended+PLM+vision/index.aspx>, Accessed: 02/02/2009.
- [6] **Iosip, M.**, PLM în construcția de mașini. O privire generală, *Simpozionul Național Proiectarea Asistată în Industria Mecanică*, Iasi, 15-17 febr. 2008
- [7] **Ivan, M.**, Proiectarea și implementarea Metodologiei cadrului Național al Calificărilor din Învățământul Superior. *Seminar Phare TVET RO 2006/018 – 147.04.01.02.03.01, Instruire și consultanță pentru dezvoltarea continuă a sectorului ÎPT – componenta Învățământ Superior*, 29th-31st January 2009, Sinaia, Romania
- [8] **John Stark Associates**, A Few Words about Concurrent Engineering, Available from: <http://www.johnstark.com/fwce.html>. Accessed: 03/03/2009
- [9] **Merticaru, V.jr., Muscă, G.**, *Relaționarea PLM cu SCM și CRM în structura IT a fabricației discrete integrate*, în: *Creșterea competitivității companiilor folosind proiectarea asistată de calculator și managementul datelor pe întreaga durată de dezvoltare a produsului*, Editura PIM, Iași, 2008, ISBN 978-973-716-918-1, pp.61-70;
- [10] **Merticaru, V.jr., Muscă, G., Axinte, E.**, *PLM in Relation to SCM and CRM, for Integrating Manufacturing with Sustainable Industrial Design*, ICOVACS 2008: International Conference On Value Chain Sustainability: Integrating Design, Logistics and Branding for Sustainable Value Creation, Izmir, Turkey, November 12-14, 2008, CD Edition;
- [11] **Merticaru, V. & Muscă, G.**, A Vision upon PLM Related to SCM and CRM, in the Frame of an Enterprise's IT Structure, *Academic Journal Of Manufacturing Engineering*, Vol.6, issue 3/2008, Ed. Politehnica, Timisoara, ISSN 1583-7904, pp.93-98.
- [12] **Meta-fore**, What is PLM, Available from: <http://www.meta-fore.com/education/index.html>, Accessed: 02/02/2009
- [13] **Musca, G., Musca, E., Merticaru, V.jr.**, *Approach on Implementing a PLM Solution into a Collaborative Engineering Network for Product Design Automation*, in *Annals of DAAAM for 2008 and Proceedings of The 19th International DAAAM Symposium "Intelligent Manufacturing & Automation: Focus on Next Generation of Intelligent Systems and Solutions"*, 22-25th October 2008, SUT-FMST, Trnava, Slovakia, ISSN 1726-9679, p.0843-0844;
- [14] **Muscă, G., Merticaru, V.jr., Ciofu, C., Cărăușu, C., Tăbăcaru, L., Muscă, E., Iosip, M.**, *Definirea conceptului PLM și implementarea unei soluții PLM la interfața dintre cercetarea academică și mediul economic*, în: *Creșterea competitivității companiilor folosind proiectarea asistată de calculator și managementul datelor pe întreaga durată de dezvoltare a produsului*, Editura PIM, Iași, 2008, ISBN 978-973-716-918-1, pp. 1-60;
- [15] **Salelkar, A.**, Strategy for Deployment of Effective PLM, Available from: <http://www.expresscomputeronline.com/20081208/technology02.shtml>; Accessed: 02/02/2009.
- [16] **Wen, Y.**, Concurrent Engineering, Available from: <http://best.me.berkeley.edu/~pps/pps/concurrent.html>, Accessed: 02/02/2009.