

DYNAMICAL IMPACT OF LIQUID PRESSURE IMPULSES AND VIBRATIONS IN THE HYDRO-FORMATION PROCESS

Boris Plahteanu, Mircea Frunza

National Inventions Institute Iasi Romania,
email: boris.plahteanu@yahoo.com

ABSTRACT

The work relates the impact of the dynamical action of the pressure impulses and vibrations, through the hydraulic medium, to the sheet billet in the plastic deformation process through hydro-formation. The theoretical pressures and forces estimated are deducted and posted, with and without pressure pulses and vibrations and the influence of the specific resonance frequency on the sheet billet. The paper presents also the experimental results regarding the possibility to convey the pressure pulses and vibrations through the hydro-formation liquid, the theoretical and experimental influence of liquid viscosity and compressibility beside the process and the theoretical and experimental method used to determine in dynamics the resonance frequency of the sheet billet in the period of changing forms due to hydro-formation action.

KEYWORDS: dynamical, hydro-formation, deformation, liquid

1. GENERAL DESCRIPTION

The work relates the impact of the dynamical action of the pressure impulses and vibrations, through the hydraulic medium, to the sheet billet in the plastic deformation process through hydro-formation.



Fig. 1 Experimental Equipment

The main experimental installation consists in a hydraulic press, a mould for hydro-formation and a high pressure hydraulic source, like in Fig. 1.

The sheet of billet is inserted inside the hydro-formation mould profiled to the final form. A hydraulic pressure is applied into the system and the deformation process is starting.

The mould (Fig. 2) has a base plate (1) where are inserted two piezoelectric actuators (4), one for exciting the system and the second for data acquisition, (3) is the sheet billet and (2) the profiled semi-mould.

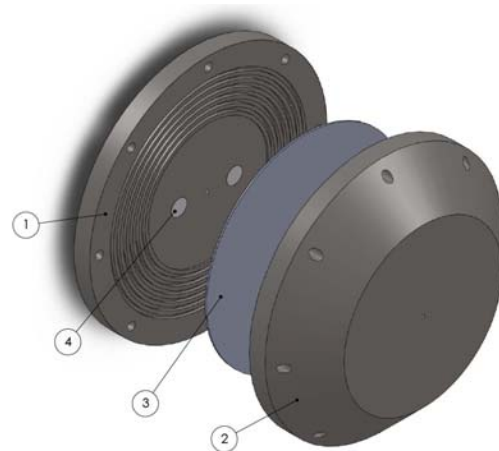

Fig. 2 Hydro-forming mould

2. CONSTRUCTION DETAILS

On the base plate is installed an innovative sealing system with multiple seals, each seal realise an approximate 24 MPa sealing pressure (Fig. 3). In these conditions with 7 seals we can seal a pressure more then 150 MPa. The gaps between the seals are connected into a stepping reduced pressure system which realise the 24MPa step with a 0.005 l/min liquid leaking.

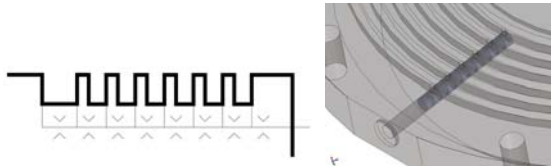

Fig.3 Multiple steps sealing system for hydro-forming sheets.

Next step is to introduce in the mould a hydraulic pressure with a constant power hydraulic source which works with the following diagram (Fig.4).

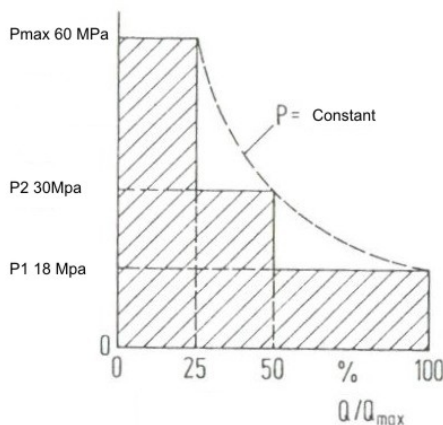

Fig. 4 Constant pressure diagram of the high pressure hydraulic source.

At the process starting a constant flow of oil at 100% of the pumping capacity will be inserted in the mould. This flow is produced by a pump which works at 3000 rpm. When the pressure is raising up to 18 MPa, an electronic device reduce the speed of the pump at 1500 rpm, the hydraulic flow descends with 50% as well as the power in the system not exceed the maximum power used for the stage 1. When the pressure reaches 300 MPa the electronic system commutes the system to the high pressure amplifier which rise the pressure up to 60-70 MPa, the final flow of the oil descends to 25% from the initial flow as well as the power used remains constant. This simple system allows a higher efficiency of the pressure generator, because in the first stage of the process we will need a lot of oil (liquid) to fill up the mould and to start the deforming process. During the deformation time the force required for deformation is rising which results in a pressure growing and when the deformation reaches 70% done, the flow

consumption in the system can decrease to 50%. When the pressure get the value of 30 MPa, the deforming process is done 98%. In this step we need the higher pressure (60-70MPa) to calibrate the sheet of billet to the final form. At this step we need a small quantity of oil but as results higher pressure. This job is done by the pressure multiplier which use the flow from the faze 2 to multiply the pressure by 4, up to the final value. The result is a hydraulic flow divided by 4 which is enough for the calibration process.

Using a simulation in SolidWorks the theoretical pressures and forces are estimated, deducted and posted, with (Fig. 5b) and without (Fig. 5a) pressure pulses and vibrations. The difference in the simulation process is a uniform distribution of the deformation force if in the system is applied pressure pulse and vibrations.

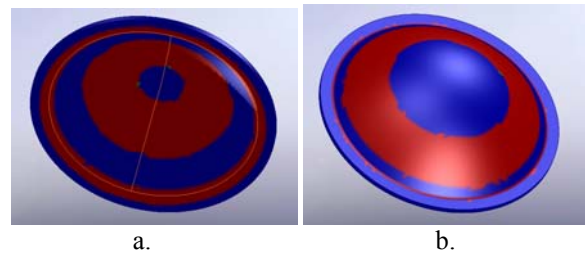

Fig. 5 Stress diagram during the Hydro-formation process with the constant high pressure

Next step is to find the influence of the specific resonance frequency of the sheet billet.

At this point a peak signal is applied through the liquid in the system through a linear piezoelectric actuator. The actuator (Fig. 6) is able to transmit also any kind of forms of signals functions, signals generated by a computer with a data acquisition interface and a power amplifier.

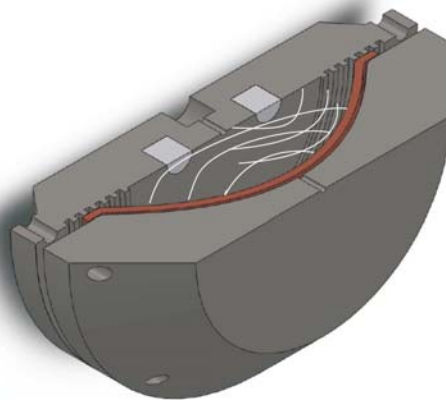

Fig. 6 Wave in the hydro-formation liquid, one piezo actuator generates and the second one receives.

The model is still experimental and the results as they are described in the chapter 3 shows that is possible to determine in the different stages of the experiment the resonance frequency of the sheet of billet. The following experiments will try to determine which is the influence of these pulses of

pressure and what is happening if in the system are inserted vibrations through the hydro-forming fluid.

3. RESULTS

Regarding the determination of the resonance frequency, the following steps were done:

On the first stage is applying a single step signal, like “sonar”. The second actuator is receiving the signal reflected from the sheet billet and through a Matlab application we found the specific response of the system (Fig. 7).

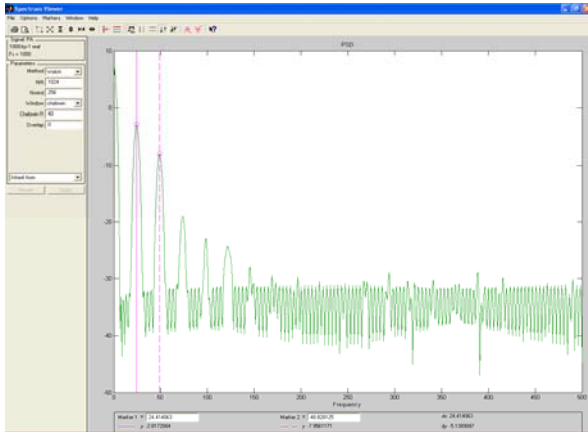

Fig. 7 The response of the system to a single impulse signal.

We analyse the signal with a filtration application in MathLab and, as we can see in the Fig. 8, we get a maximum of the natural high magnitude of the signal response from the system base frequency at 43,09 Hz and a lowest point at 24,65 Hz. The second part of the part of the application, with a zero pole editor, shows that at the system is stable if it is excited at 24 Hz. This observation is very important because is the first step in the experimental process of stimulation the sheet billet with impulses and vibrations. The experiment was made with a 80% deformation to the final form of the sheet billet.

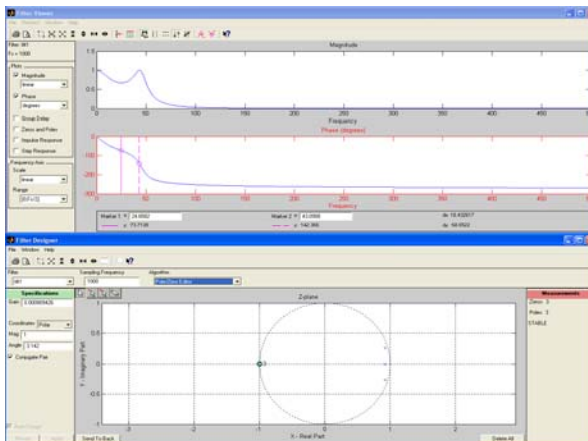

Fig. 8 The natural resonance frequency 24Hz and system stability founded with a Matlab application.

Next stage was to simulate what is happening with the sheet if a dynamic signal is applied. The simulation was made in Cosmos at the 24Hz frequency.

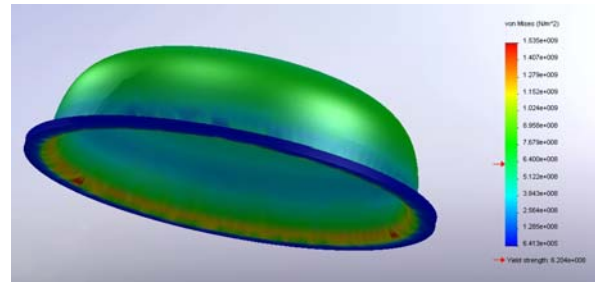

Fig.9 Stress diagram during the Hydro-formation process with a dynamic vibration induced in the hydraulic fluid

As we can see in the Fig. 9 using dynamical pulsations liquid pressure the results will be a very good shape of the final product obtained with a small quantity of energy and a uniform distribution of the efforts in the metal sheet.

Next experiment was on the third stage to apply a continuous pressure signal in-to the hydro-formation liquid. The signal received from the second actuator with a labview interface is saved in a database on the hard disc and analysed with the same Matlab application are presented in Figs. 10 and 11..

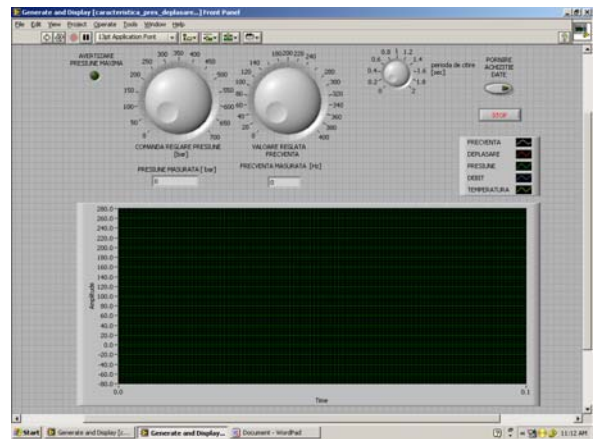

Fig. 10 Lab View interface for pressure and frequency acquisition

The database created by the Labview application has the following form:

Date	Time	0	1	2	3	...
10.11.2008	10:05:29	9,995	2,632	-2,271	-0,659	...
10.11.2008	10:05:35	1,313	2,139	-0,664	-0,269	...
10.11.2008	10:05:40	0,498	1,538	0,112	-0,029	...
10.11.2008	10:05:45	0,068	0,986	0,327	-0,005	...
10.11.2008	10:05:50	-0,298	0,542	0,356	0,015	...
10.11.2008	10:05:55	-0,186	0,288	0,269	-0,010	...

This database was imported in Matlab with a signal browser and the results were posted in the diagram from the figure 11. The figure represents a part of the all browser image magnified. In the image we can see that the signal received has a smooth form

on the top at the highest value of the pressure and a sharp one at the bottom where the lowest value of the pressure is.

That phenomena show that the sheet of billet reacts to the pressure pulses.

At the top of the signal the smooth form indicate that the deformation is placed in the plastic area, continuous deformation.

At the bottom, in the lowest pressure area, the sheet of billet reacts in an elastic mode, we have no deformation.

In conclusion the dynamic deformation process is characterised by a deformation in steps which means like we had a lots of small deformation processes in series, with small amplitude which generates at a specific frequency a continuous deformation of the sheet.

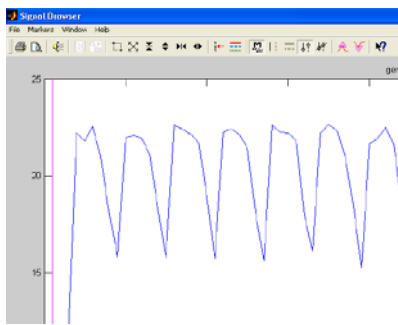

Fig. 11 Detail of the received signal imported from the database by the application in Matlab.

In this faze of the experiment we try to found what was happening in the mould when the vibration are transmitted through the hydro-formation fluid. Is in a way the system influenced by these vibrations?

It is possible to “see” and discover this influence only by analyze of the response of the signal reflected from the sheet?

The response of the peak signal reflected by the sheet recorded with the Labview application, transformed into a digital data by the acquisition interface, filtered and analysed by computer software application in Matlab suggests that indeed exists a specific frequency where the system acts in the way discussed at the previous point.

But this frequency had multiple harmonics till in the field of higher frequencies.

The software identifies the specific resonance frequency of the system at different stages of deformation and analyse the response of the sheet.

In Fig. 12 for the signal analyses was used a Matlab band-pass filter with a Chebyshev Type I R algorithm, which illustrates the response of the system at a simulation frequency about 24 Hz.

We can see, multiplying by 10, that the domain where the system responding as active is limited between 48 and 275 Hz, but can be used from 24 until 350 Hz.

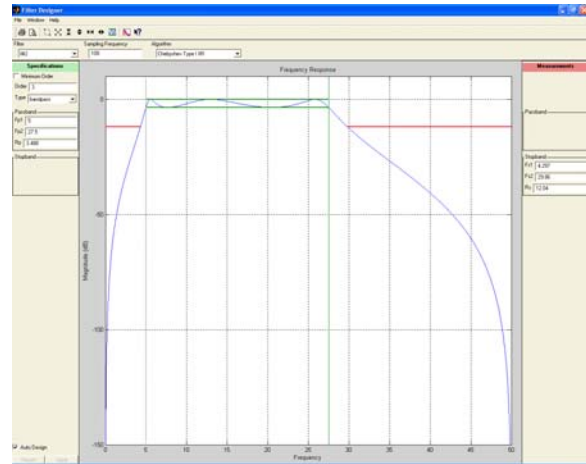

Fig. 12 The domain of active response of the system at a stimulation frequency 24Hz

In Fig. 13 is analysed the system response from the point of view Magnitude (linear mode) – Frequency (x10 Hz) and Phase(radians)- Frequency (x10 Hz).

The diagram indicates also that the efficient frequency is between 24-350Hz with an optimum between 48-275Hz.

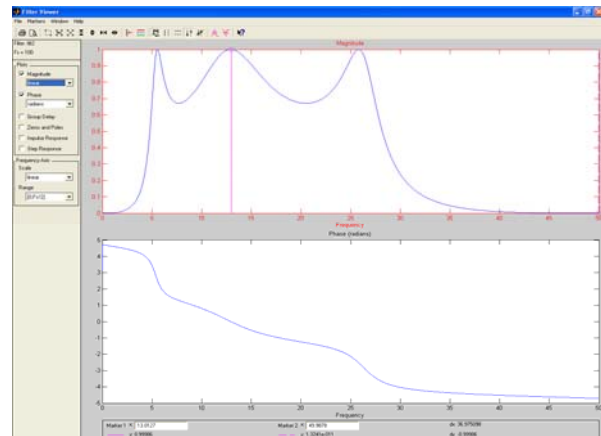

Fig. 13 The response of the system at a stimulation frequency 24Hz, the diagram of magnitude-frequency and phase frequency values.

In Fig. 14 is posted a spectrum analyse of the signal reflected from the sheet-billet analyzed with the Welch method in a Hanning window.

The diagram shows that the system reacts and amplifies some frequencies like 16.69 Hz, 33.00 Hz, and 66.69 Hz ... from approximate 17 to 17 Hz.

Those frequencies are not very different during the all deformation process which means that they depends by the surface , thickness and quality of the material involved in the deformation process.

It is evident that the construction of the mould has a bigger importance but for the fame shape of the sheet of billet the most important one is those three parameters mentioned below.

The importance of this thing is that at a specific form and material has a specific approximate constant stimulating frequency. In this way can by build a database with the results of the research which can be applied in the industrial process like a local standard.

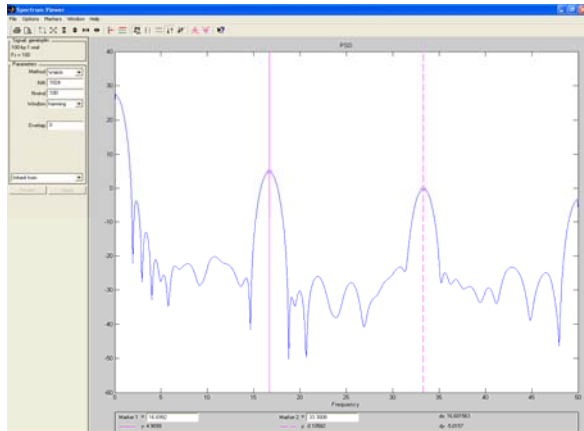

Fig. 14 Main exiting frequencies

As this thing was done next step is to build an application, in Labview, for controlling the entire cycle of hydro-formation process (Fig.15).

This was including the command buttons for pressure control, frequency control and temperature control and the measuring and data acquisition modules.

These modules will display and record all the values of the programmed process parameters and measure the physical value of the: hydro-forming pressure, stimulation frequency (signal from the second piezoelectric actuator), temperature, used flow of the hydro-formation liquid, displacement of the sheet of billet in the central point of the mould.

The system has the possibility to control the period of reading the data from continuous (200000 readings/s) to one read at each two seconds or more.

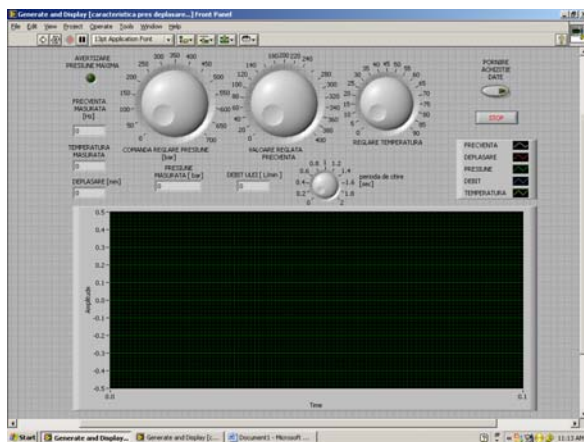

Fig 15. Labview Interface for dynamic hydro-formation laboratory application

Another interesting part of the application is to determine the influence of the temperature about the hydroforming process.

This research for temperature influence was projected to be done in two steps. First step is just to supervise and read the temperature on the system.

From the first tests we work with hydraulic oil like hydro-formation liquid at a initial temperature about 35 C degrees. During the first hydro-formation experiments the temperature are slowly raising from 35 to 40-45 C degrees. But for an accurate experiment we must use an adiabatic environment for the mould.

Second step is projected to be a future experiment and is related with the importance of the value of the hydro-formation temperature to the system and the quality of the hydro-formation sheets of billets when the adiabatic environment will be ready.

4. CONCLUSIONS

- National Inventics Institute in collaboration with Technical University Gheorghe Asachi of Iasi has a long experience in hydro-formation, first experiments was started in 1985 with parabolic antennas and lots of blades and rotors for pumps and turbines.

- From 2007 a new research project regarding hydro-formation with high pressures was developed in partnership between National Inventics Institute and the laboratories of Hydraulics and Pneumatics of the Machine Tools Department of the Faculty of Machine Manufacturing and Industrial Management from the Technical University Gheorghe Asachi of Iasi.

- The project was focused on Hydroformation of different types of sheets with very complex surfaces and tubes in “T”, “Y”, and some nonconventional forms.

- From the very beginning we faced with an inconvenient related to the elasticity of some materials. This problem was partially solved (85%) using high pressures (150 MPa), but the final shape was easier affected.

- This inconvenient gave us the idea to use for final calibration a hydraulic high pressure pulse. The results were satisfactory; the final shape corresponds in the proportion of 93-95% with the mould.

- A better results where achieved if the pulse was applied when the shape of billet was deformed only in proportion of 75%. In this way the final form was obtained from a single operation of plastic deformation from 75% to 95-96%.

- The next step was to find a way to apply a series of pressure pulses to calibrate the sheet to final shape. This problem was resolved by introducing the two

piezoelectric actuators in the construction of the mould, one for exiting the system and the second one to listen and collect the data.

- The results will be a better good shape of the final product obtained with a small quantity of energy.

- The existence of harmonic frequencies in the system help us to understand that the stimulating dynamic signal can be by the order of KHz, multiple of the main frequency. The sheet can be stimulated with a higher frequency even in the domain of ultrasounds. This will be the next step of experimental researches.

- The vibration accorded with one of the specific frequency of the sheet, as is described in chapter three, acting like a series of small plastic deformation, will reduce the force necessary for deformation and proportional with this the value of the working pressure.

-The deformation process using only vibrations is not a technology but the hydro-formation with pressure impulses and vibrations is not very well known at this moment and can be an alternative to the future of the processes based on.

-The theoretical and experimental influence of liquid viscosity and compressibility beside the process influence the value of the stimulating frequencies. A detailed study of those influences will be part of future researches.

- The theoretical and experimental method used to determine in dynamics the resonance frequency of the sheet billet in the period of changing forms due to hydro-formation action is still experimental and will be improved in the future using the Labview interface for data acquisition and signal conditioning.

-The first experiments were done only in the final stage of the deforming process. The future experiments are planned to use vibrations during the all period of deformation process.

-Another planned experiment in to use both piezoelectric actuators to generate waves with different amplitude and frequency, the cumulative effect of those waves will be part of future researches.

- Using a large spectre of stimulating frequencies we will try to define the right one for any kind of material.

- We also will try to create a database with these results including the dependency of the thickness, rheological properties and sheet surface.

- If we think in the future a lot of identified and not identified problems could appear in this area of research and a lot of steps must be covered to an efficient technology based on hydro-formation with impulses and vibrations.

- A very important direction is the influence of the vibration regarding the hydro-formation liquids the life-working period and the general problems with the ecological environment and safety operations.

REFERENCES

- [1] **Frunză, M., Plahteanu, B., Chiriță, C.,** *Dinamical simulation of the self commanded hydrostatic vibrations and impulses generators, with elements of logical command (Hidrologistors), using mathematical programing medium Matlab-Simulink, Tehnologii moderne Calitate Restructurare, TMCR Chișinău 2003, Vol IV, pag 11.*
- [2] **Frunză, M., Plahteanu, B., Chiriță, C.,** *Optimizarea funcțional constructivă a elementelor de comandă logice (hidrologistori), pentru folosirea lor în construcția generatoarelor de impulsuri hidrostatice (Pickhammer), Hervex 2002 Salon Național de hidraulică, pneumatică, elemente de etansare, mecanica fină, scule, dispozitive și echipamente electronice specifice, mecatronica.*
- [3] **Frunză, M., Plahteanu, B.,** *Functioning and regulating characteristics of the interactive hydrostatic impulses generators, with elements of logical command (Hidrologistors), Buletinul Institutului Politehnic Iași, Universitatea Tehnică Gh. Asachi Iași, Tomul XLVII (LI), Supliment Mașini-Unelte și Scule, Secția Construcții de Mașini.*
- [4] **Frunză, M., Plahteanu, B.,** *The interactive control of the amplitude and of the working frequency of the self commanded hydrostatic vibrations and impulses generators, with elements of logical command (hidrologistors), Tehnologii moderne Calitate Restructurare, TMCR Chișinău 2001, Vol I, pag 521.*
- [5] **Frunză, M., Plahteanu B., Chiriță C.,** *Dynamical simulation of the self commanded hydrostatic vibrations and impulses generators, with elements of logical command (hidrologistors), using mathematical programming medium math lab – simulink. Chisinau 2003*
- [6] **Plahteanu, B., Chirita, C., Frunza, M., Jipa, C.,** *Research for innovative and flexible system for high performance plastic deformations through hydroforming with high pressure, The International Conference on Hydraulic Machinery and Equipments Timisoara, Romania, October 16-17, 2008*
- [7] **Frunză, M., Plahteanu B.,** *Modelarea unei structuri hidrostatice pentru hidro-formarea unei game tipizate de carcase si semicarcase pentru acumulatele destinate instalații hidraulice fixe și mobile, Hervex Noiembrie 2008*
- [8] **Plahteanu, B., Frunza, M.,** *Self oscillatory high pressure (70 mpa) multipliers, with logic hydraulic elements, for hydro-formation liquids. Simulation of dynamic operation - Proceedings of the 17th International Conference on Manufacturing Systems – ICMA5, ISSN 1842-3183*
- [9] **Chirita, C., Hanganu A.C.,** *Prese hidraulice de hidroformare cu echipament hidraulic de 700 bari – structura inovativa cu tehnologie pe produse speciale*
- [10] **Frunza, M.,** *Contribuții la optimizarea funcțional constructivă a generatoarelor de impulsuri hidrostatice cu aplicații în procesele de lucru și încercare a mașinilor și sistemelor integrate de mașini, Teza de doctorat 2004.*